

Getting Started with Modbus™ RTU for AC Tech Drives

Contained herein is the basic information for setting up AC Tech SMV Inverter and PositionServo drives for Modbus RTU communication. For detailed information on the Modbus option module, refer to the product's Modbus Communication Reference Guide (SMV: CMVMB401, PositionServo: P94MOD01). Topics discussed in this application note include RS232, RS485, cabling, number of masters and slaves, termination, function codes and register numbering.

For Further Reference

Modbus-IDA: <http://www.modbus-IDA.org>
AC Tech Library: <http://www.actech.com>

Common Terms

CIP™ Common Industrial Protocol
DCE Data Communications Equipment
DTE Data Terminal Equipment
HMI Human Machine Interface (the physical layer between the human and the machine, a.k.a MMI, operator terminal, touch screen)
Modbus Open fieldbus standard for a multi-drop network based on master/client architecture
Protocol Set of rules about communication on a network. Rules on: syntax (data format); semantics (interpretation of data); timing (transmission agreement between sender and receiver)
RTU Remote Terminal Unit
SCADA Supervisory Control And Data Acquisition. In North America, SCADA is a large-scale, distributed measurement and control system.

Modbus Basics

Maximum number of Modbus masters: Modbus as a protocol allows only a single master to exist on any given network. A Modbus master is any device that initiates a Modbus message, whether that be a read or a write. Common Modbus master devices used with drives include: HMIs (also referred to as MMIs and operator terminals), PLCs, SCADA devices, and PCs when used for data collection or programming. Only a Modbus master can initiate Modbus communication

Maximum number of slaves: Modbus slaves respond to write and read requests from Modbus masters. All AC Tech drives operate only as Modbus slaves. Modbus as a protocol allows for a maximum of 247 slaves; however the network hardware will limit this significantly. See RS-232 and RS-485 sections herein.

Slave addresses: Valid Modbus slave addresses are from 1-247. Address 0 is a special address used for broadcast messages in Modbus protocol. A broadcast message is a write command given to all Modbus slaves on the network at the same time. At this time AC Tech drives do not support Modbus broadcast messaging

COM parameters: Every device (master and slaves) on a given Modbus network must be set to the exact same COM parameters and baud rate. All AC Tech drives utilize Modbus RTU (8 data bits). They cannot be configured for Modbus ASCII (7 data bits). Table 1 lists the baud rate, parity and number of stop bits for AC Tech drives with Modbus capability.

Table 1: AC Tech Drive COM Parameters

Drive	Baud Rate	Parity	Stop Bits
MC Series	9600	None	2
SCF	9600	None Even Odd	2 1 1
SMV	2400, 4800, 9600, 19200, 38400, 57600 or 115200	None Even Odd	2 or 1 1 1
PositionServo	2400, 4800, 9600, 19200, 38400, 57600 or 115200.	None Even Odd	2 or 1 2 or 1 2 or 1

Modbus register addressing: All AC Tech drives use only 4X registers for data messaging. Consult with the product's user manual for a register mapping table.



Note:

Modbus 3X and 4X registers are numbered starting at 1. However, when transmitted to a slave over the serial link, the actual address transmitted is one less. This is because the addresses are numbered starting from 0.

AC Tech register numbers are also numbered starting from 0. Therefore, AC Tech register numbers always correspond exactly with the address transmitted. As a result, Modbus register numbers are always one greater than AC Tech register numbers. Whenever the words "REGISTER #XX" appear, it should be assumed that they mean "AC TECH REGISTER XX" and the Modbus register number will be one larger. In some instances, both are shown for clarity: Register #24 (Modbus Register #25).

Supported Modbus function codes: As a rule, use Modbus function codes 3 (read 4X holding registers) and 16 (write 4X holding registers) for communications. Most register reads and writes must be done one register at a time. As a result a series of writes are required to start a drive. Each product's user manual contains application notes for commanding start and changing speed. Refer to the individual product's user manual.

RS-232

Used on: the EPM programmer and the 940 PositionServo's programming port

Cabling: The EPM programmer has an RS-232 interface to connect it directly to a computer using a standard 9-pin serial cable with a male connector (DB9M) for the EPM connection and a female (DB9F) for the computer connection. These are straight through connections of pins 2, 3 and 5. Do not use a "null modem" cable as this cable internally crosses pins 2 and 3. The same is true for the PositionServo. Use a straight-through connection for pins 2, 3 and 5.

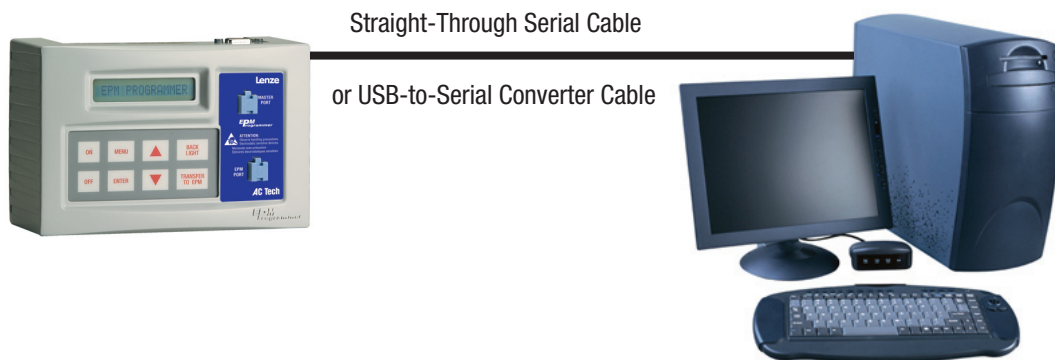

Figure 1: EPM RS232 Connection

The actual pin designations are:

RX 2 -> 2 TX

TX 3 -> 3 RX

GND 5 -> 5 GND

Both the EPM programmer and the 940 PositionServo operate as DTE (Data Terminal Equipment) type devices. PCs also act as DTE type devices. When connecting two DTE devices together RX and TX are crossed between them. This means RX of one device connects to TX of the other device.

Some devices, such as some RS-232/485 communications converters actually run as DCE (Data Communications Equipment) type devices. If you need to connect a DCE type device to a DTE type device, RX needs to be connected to RX and TX needs to be connected to TX on both devices. In some cases, devices may require “full handshaking”.

RX -> RX

TX -> TX

GND -> GND

Neither the 940 PositionServo nor the EPM programmer support RTS/CTS or DTR/DSR handshaking. To get around this requirement simply add in two jumpers to the cable at the side of the device requiring the handshaking.

Jumper RTS to CTS

Jumper DTR to DSR

Do not run these pins across to the other side of the cable.

Recommended cable: Several cable types are offered by various manufacturers for serial RS-232 cabling applications. One example from Belden used in standard applications is the Belden 8777 cable.

Termination: No termination is required for RS-232.

Recommended maximum cable length: 50 feet.

Maximum number of slaves: RS-232 is a point to point media. It can only connect two devices together (one Modbus master to a single Modbus slave).

RS-485

Used on: SCF, MC, MCH, SMVector, and 940 PositionServo

Cabling: NOTE: ground shield drain wire at only one end.

Note: On the SCF, MC and MCH drives be sure to tie pin 2 to chassis ground. On the SMVector drive be sure to tie pin 1 of the Modbus terminal strip (not the control terminal strip) to ground.

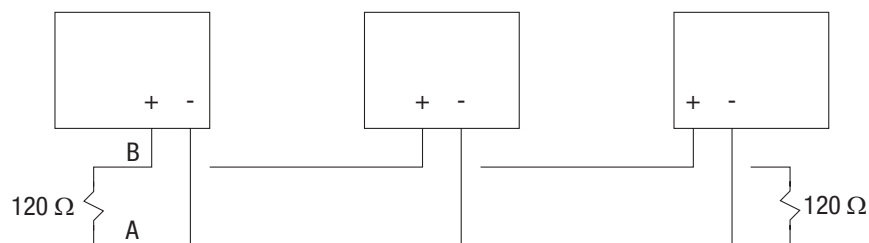

Figure 2: Cabling

Recommended cable: Several cable types are offered by various manufacturers for RS-485 applications. One example from Belden used in standard applications is the Belden 9842 cable. Belden 8777 cable could be used for 4-wire RS-485, however it has more leads than needed for 2-wire RS-485 applications.

Termination: 120 Ohms +/-1% resistors installed between A and B wires at either end of the network.

Recommended maximum network length: 500 meters

Maximum number of slaves: This is dependent on the MB master. Typically can be 8 or 16; however more slaves are possible. Check with the manufacturer of the MB master.

RS-232/485 converters: RS-232 and RS-485 are electrically different media. If you need to connect an RS-232 device to an RS-485 device or network, you will require an RS-232/485 converter. These are readily available from most electronics stores.

FAQ:

Can I connect a PC serial port to the MB RS-485 port on an AC Tech drive?

Not directly. You will need an RS-232/485 converter and will need to make up both RS-485 and RS-232 cabling. RS-232/485 converters are readily available from computer and electronics stores.

Can I hook both a PLC and an HMI up to the same drive?

Not directly. Only one MB master can exist on any one MB network. Some PLCs have multiple MB ports. If yours does and can act as a MB master on one port and slave on the other, the HMI could be the master to the PLC on one network (port) while the PLC could act as the MB master to the drives from its MB master port. The HMI would not be able to poll the drives directly. The PLC would need to act as a data concentrator. This requires programming be done in the PLC.

Can I get a Modbus device to communicate MB TCP/IP?

There are third party bridges available. Lantronix, for example, offers several models. Take care to ensure the COM parameters (MB RTU, 8, n, 2) are supported to ensure compatibility.

Can I hook up a 4 wire MB master to the drive?

Yes. A 4-wire RS-485 device can be connected to a 2 wire RS-485 network by following the wiring diagram in Figure 4.

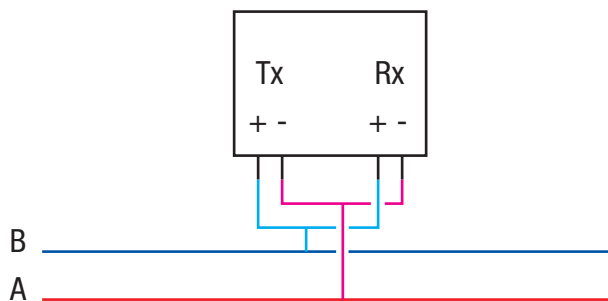

Figure 3: 4-Wire Modbus Master

- i** **Note:**
For the drive to take start/stop commands from the Modbus master, set the drive's control source to NETWORK CONTROL. To allow the drive to take speed reference commands from the Modbus master, set the drive's speed reference to NETWORK REFERENCE.
- ! WARNING!**
Never reset a faulted drive locally! Always reset via the Modbus master. Failure to do so may result in unexpected operation.
- ! WARNING!**
Always send a low rotation speed command to a drive prior to changing direction. If both the direction and the speed setpoint are programmed to change at the same time, the drive may for a short time change direction and run at the wrong speed.