

SMVector RS-485 LECOM Communication Module
Communications Interface Reference Guide



About these instructions

This documentation applies to the RS-485 / LECOM communications option for the SMVector inverter and should be used in conjunction with the SMVector Operating Instructions (Document SV01) that shipped with the drive. These documents should be read in their entirety as they contain important technical data and describe the installation and operation of the drive and this option.



WARNING!

The information in this document is based on RS-485 LECOM Communication Module software version 1.20. If a future revision of software contains differences in the register numbering or register definitions, drive operation could be seriously affected. If drive parameter P494 does not display **1.20**, then writing to any drive register over the network **MUST NOT BE ATTEMPTED** as it would have the potential for unexpected consequences potentially resulting in damage to the equipment or harm to personnel. Future releases of module software require that the appropriate documentation be used for implementation.



NOTE

To use the LECOM option of the RS-485 communication module with the SMVector (0.33-10HP) requires standard software version 3.0 or later. All SMVector 15HP (11kW) and higher models support the LECOM option on the RS-485 communication module.

© 2008 Lenze AC Tech Corporation

No part of this documentation may be copied or made available to third parties without the explicit written approval of Lenze AC Tech Corporation.

All information given in this documentation has been carefully selected and tested for compliance with the hardware and software described. Nevertheless, discrepancies cannot be ruled out. We do not accept any responsibility nor liability for damages that may occur. Any necessary corrections will be implemented in subsequent editions.



1	Safety Information	2
1.1	General	2
1.2	Application	2
1.3	Installation.....	2
1.4	Electrical Connection	2
1.5	Operation	3
2	Introduction	4
2.1	Module Specifications	4
2.2	Module Identification Label.....	4
3	Installation	5
3.1	Mechanical Installation	5
3.2	RS-485 Terminal Block.....	6
3.3	Electrical Installation.....	6
3.3.1	Cable Types.....	6
3.3.2	Network Limitations.....	6
3.3.3	Connections and Shielding.....	6
3.3.4	Network Termination	7
4	Parameters for use with RS-485/LECOM.....	8
4.1	Drive Communication Parameters.....	8
4.2	RS485 LECOM-Specific Parameters	9
5	LECOM Protocol Details	10
5.1	LECOM - A/B Protocol Description	10
5.2	Controller address (AD1, AD2)	10
5.3	Code Number (C1, C2).....	11
5.3.1	Standard Addressing.....	11
5.3.2	Addressing via Code Bank	11
5.3.3	Addressing via Input Selection	12
5.3.4	Extended Addressing	12
5.4	Parameter Value (V1 to Vn)	12
5.5	Block-Check Character (BCC)	14
6	LECOM Message Details	15
6.1	Telegram Response.....	15
6.2	Receive Telegram.....	15
6.3	Receive Telegram Response.....	15
6.4	Send Telegram	16
6.4	Broadcast / Multicast.....	17
7	Commissioning	18
7.1	Drive Monitoring.....	18
7.2	Drive Programming and Control.....	18
7.3	Network Watchdog Timer	18
7.3.1	Watchdog Timer	18
7.3.2	Watchdog Time-out Period (P425).....	18
7.3.3	Watchdog Time-out Action (P426).....	18
8	Drive Registers	19
8.1	Configuration and Control Registers.....	19
8.1.1	C1050 (Network Controlled Digital Output)	22
8.1.2	C1055 (Network Controlled Analog Output)	22
8.1.3	C1099 (Parameter Version)	22
9	Programming Parameters	23
9.1	Fault History (P500).....	23
9.2	Drive ID (P502)	24
9.3	Terminal and Protection Status (P530).....	25
9.4	Keypad Status (P531)	25
10	Troubleshooting and Fault Elimination.....	26
10.1	Faults	26
10.2	Troubleshooting.....	26



1 Safety Information

1.1 General

Some parts of Lenze controllers (frequency inverters, servo inverters, DC controllers) can be live, moving and rotating. Some surfaces can be hot.

Non-authorized removal of the required cover, inappropriate use, and incorrect installation or operation creates the risk of severe injury to personnel or damage to equipment.

All operations concerning transport, installation, and commissioning as well as maintenance must be carried out by qualified, skilled personnel (IEC 364 and CENELEC HD 384 or DIN VDE 0100 and IEC report 664 or DIN VDE0110 and national regulations for the prevention of accidents must be observed).

According to this basic safety information, qualified skilled personnel are persons who are familiar with the installation, assembly, commissioning, and operation of the product and who have the qualifications necessary for their occupation.

1.2 Application

Drive controllers are components designed for installation in electrical systems or machinery. They are not to be used as appliances. They are intended exclusively for professional and commercial purposes according to EN 61000-3-2. The documentation includes information on compliance with EN 61000-3-2.

When installing the drive controllers in machines, commissioning (i.e. the starting of operation as directed) is prohibited until it is proven that the machine complies with the regulations of the EC Directive 2006/42/EC (Machinery Directive); EN 60204 must be observed.

Commissioning (i.e. starting drive as directed) is only allowed when there is compliance to the EMC Directive (2004/108/EC).

The drive controllers meet the requirements of the Low Voltage Directive 2006/95/EC. The harmonised standards of the series EN 50178/DIN VDE 0160 apply to the controllers.

The availability of controllers is restricted according to EN 61800-3. These products can cause radio interference in residential areas. In the case of radio interference, special measures may be necessary for drive controllers.

1.3 Installation

Ensure proper handling and avoid excessive mechanical stress. Do not bend any components and do not change any insulation distances during transport or handling. Do not touch any electronic components and contacts. Controllers contain electrostatically sensitive components, which can easily be damaged by inappropriate handling. Do not damage or destroy any electrical components since this might endanger your health! When installing the drive ensure optimal airflow by observing all clearance distances in the drive's user manual. Do not expose the drive to excessive: vibration, temperature, humidity, sunlight, dust, pollutants, corrosive chemicals or other hazardous environments.

1.4 Electrical Connection

When working on live drive controllers, applicable national regulations for the prevention of accidents (e.g. VBG 4) must be observed.

The electrical installation must be carried out in accordance with the appropriate regulations (e.g. cable cross-sections, fuses, PE connection). Additional information can be obtained from the regulatory documentation.

The regulatory documentation contains information about installation in compliance with EMC (shielding, grounding, filters and cables). These notes must also be observed for CE-marked controllers. The manufacturer of the system or machine is responsible for compliance with the required limit values demanded by EMC legislation.



1.5 Operation

Systems including controllers must be equipped with additional monitoring and protection devices according to the corresponding standards (e.g. technical equipment, regulations for prevention of accidents, etc.). You are allowed to adapt the controller to your application as described in the documentation.



DANGER!





- After the controller has been disconnected from the supply voltage, do not touch the live components and power connection until the capacitors have discharged. Please observe the corresponding notes on the controller.
- Do not continuously cycle input power to the controller more than once every three minutes.
- Close all protective covers and doors during operation.



WARNING!

Network control permits automatic starting and stopping of the inverter drive. The system design must incorporate adequate protection to prevent personnel from accessing moving equipment while power is applied to the drive system.

Table 1: Pictographs used in these instructions

Pictograph	Signal Word	Meaning	Consequences if Ignored
	DANGER!	Warning of Hazardous Electrical Voltage.	Reference to an imminent danger that may result in death or serious personal injury if the corresponding measures are not taken.
	WARNING!	Impending or possible danger for persons	Death or injury
	STOP!	Possible damage to equipment	Damage to drive system or its surroundings
	NOTE	Useful tip: If observed, it will make using the drive easier	



2 Introduction

This reference guide assumes that the reader has a working knowledge of the LECOM Protocol and familiarity with the programming and operation of motion control equipment. This guide is intended as a reference only.

2.1 Module Specifications

Table 2 identifies the LECOM serial communication specifications. If the specification is fixed (non-adjustable) the value is shown under "Range", if the specification is selectable, the table identifies the Parameter and available range of selections.

Table 2: LECOM Serial Communication

Description	Type	Range
Network Address	Selectable	P410 (1 - 99)
Baud Rate	Selectable	P411 (9600, 4800, 2400, 1200, 19200 bps)
Data Bits	Fixed	7
Parity / Stop Bits	Fixed	Even/1

Typical communications between master and slave would be:

- Write commands from Master
 - Run command
 - Frequency Reference
 - Modification of Drive operating parameters
- Requests from Master
 - Reporting of drive status
 - Fault status (and fault history)

2.2 Module Identification Label

Figure 1 illustrates the labels on the SMV RS-485 communications module. The SMVector RS-485 module is identifiable by:

- Two labels affixed to either side of the module.
- The color coded identifier label in the center of the module.

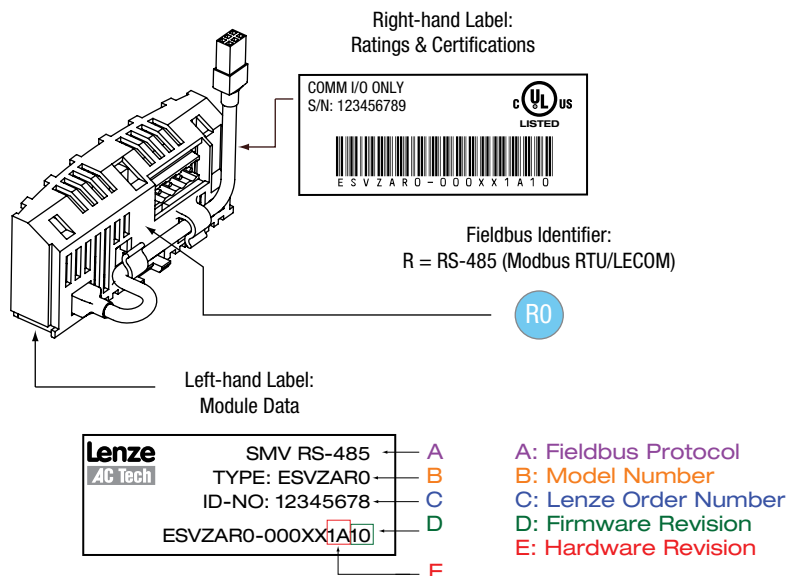

Figure 1: RS-485 Module Labels



3 Installation

3.1 Mechanical Installation

1. Ensure that for safety reasons the AC supply has been disconnected before opening the terminal cover.
2. Insert the RS-485 option module in the terminal cover and securely “click” into position as illustrated in Figure 2.
3. Wire the network cables to the connector provided, as detailed in paragraphs 3.2 (RS-485 Terminal Block) and 3.3 (Electrical Installation), and plug the connector into the option module.
4. Align terminal cover for re-fitting, connect the module umbilical cord to the drive then close the cover and secure, as shown in Figure 3.

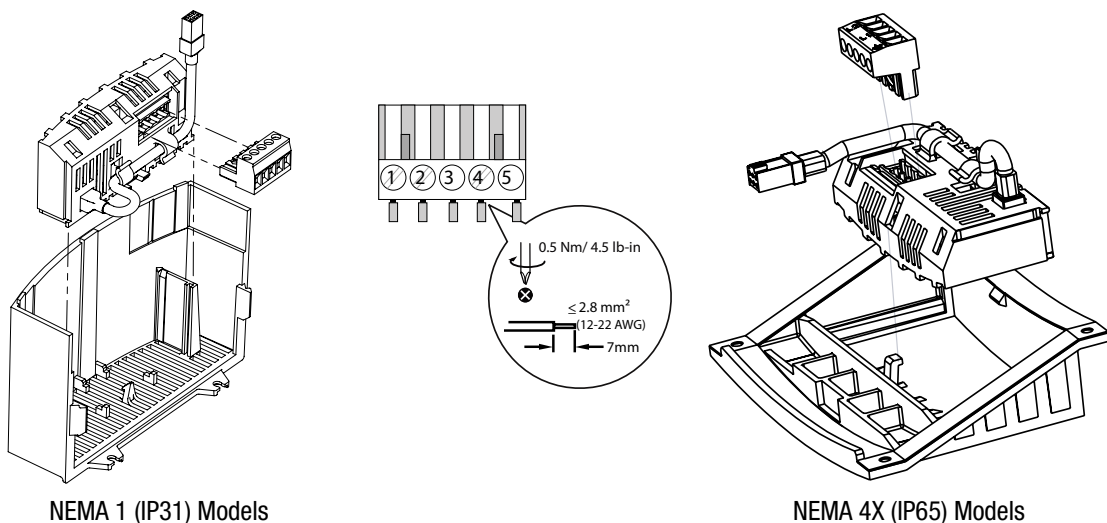

Figure 2: Installing the RS-485 Communications Module

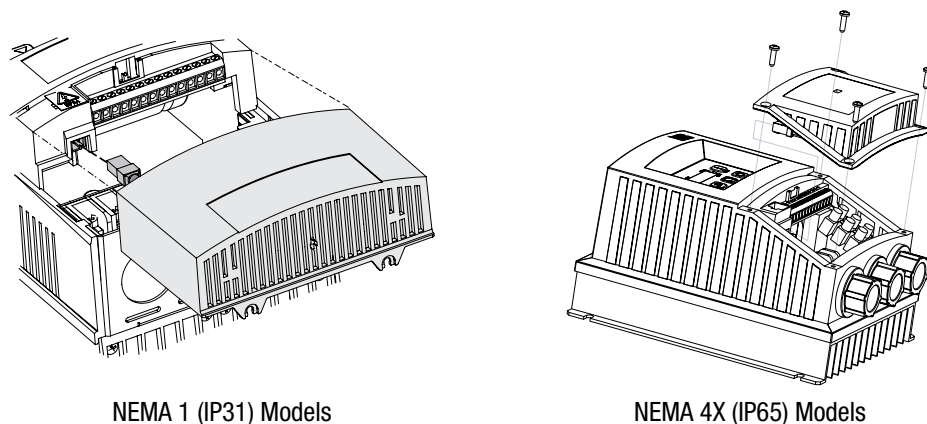

Figure 3: Re-installing the Terminal Cover



Installation

3.2 RS-485 Terminal Block

For a LECOM network, wire the RS-485 connector as detailed in Table 3.

Table 3: RS-485 Pin Designation

Terminal	Description	Important	RS-485 Connector
1	Earth ground / shield	For reliable communication make sure terminal is connected to the LECOM network GND/common. If only two wires are used (TXA and TXB) in the network, connect Terminal 1 to chassis/earth ground.	
2	TXA	If controller is located at either end of the network, a terminating resistor (120ohm typical) should be connected across TXA and TXB	
3	No connection		
4	TXB		
5	No connection		

Protection against contact

- All terminals have basic isolation (single insulating distance)
- Protection against contact can only be ensured by additional measures (i.e. double insulation)

3.3 Electrical Installation

3.3.1 Cable Types

For RS-485 LECOM-B networks, use a quality shielded twisted pair cable. The use of low quality cable will result in excess signal attenuation and data loss.

3.3.2 Network Limitations

There are several limiting factors that must be taken into consideration when building an RS-485 LECOM network:

- LECOM-B networks are limited to: 31 devices (w/o repeaters); 90 w/ repeaters).
- Topology: Without repeaters: line; with repeaters: line or tree.
- Maximum total network length is 1200 m depending on the baud rate and cable used.
- Minimum of 1 meter of cable between nodes.

3.3.3 Connections and Shielding

To ensure good system noise immunity all networks cables should be correctly grounded:

- Minimum grounding recommendation: ground the network cable once in every cubical.
- Ideal grounding recommendation: ground the network cable on or as near to each drive as possible.
- For wiring of cable to the connector plug the unscreened cable cores should be kept as short as possible; recommended maximum of 20mm. The shield connection of terminal 1 should also be wired to earth (PE).

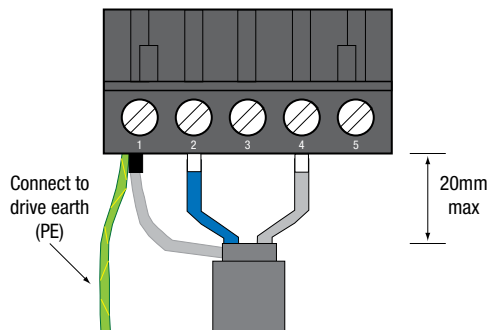

Figure 4: Connector Wiring Diagram



3.3.4 Network Termination

For an RS-485 network it is essential to install the specified termination resistors (120Ω), i.e. one at both ends of a network segment. Failure to do so will result in signals being reflected back along the cable which will cause data corruption.

An external 120Ω 1/4W resistor can be connected as shown in Figure 5.

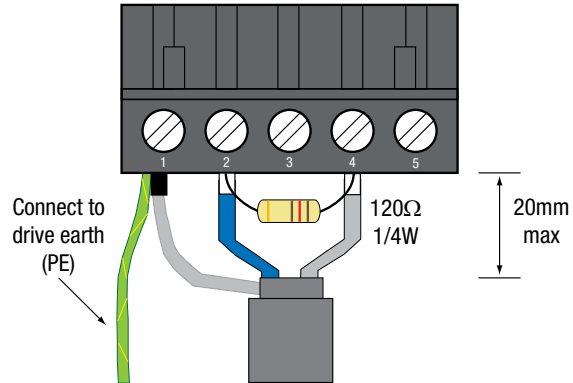

Figure 5: Network Termination Resistor



Commissioning

4 Parameters for use with RS-485/LECOM

4.1 Drive Communication Parameters

The parameters listed in Table 5 are always present on the drive, even if there is no communication module installed.

Table 5: Drive Communication Parameters

Code		Possible Settings		IMPORTANT	
No.	Name	Default	Selection		
P400	Network Protocol		0 Not Active		
			1 Remote Keypad		
			2 Modbus RTU		
			7 LECOM-B		
P401	Module Revision	01.0.0	Display reads 01.x.x where: 01 = RS485/Remote Keypad Module x.x = Module Revision	Read only	
P402	Module Status	0	0 Not Initialized	Read only the communications between the drive and module are working properly.	
			1 Initialization: Module to EPM		
			2 Initialization: EPM to Module		
			3 Online		
			4 Failed Initialization Error		
			5 Time-out Error		
			6 Initialization Failed		Module type mismatch (P400)
			7 Initialization Error		Protocol Selection mismatch (P400)
P403	Module Reset	0	0 No Action	Returns module parameters 401...499 to the default values shown in this manual.	
			1 Reset Module parameter values to default.		
P404	Module Time-out Action	3	0 Ignore	<ul style="list-style-type: none"> Action to be taken in the event of an SPI Time-out. SPI Time-out is fixed at 200ms. 	
			1 STOP (refer to P111)		
			2 Quick Stop		
			3 Fault (F _{ntF})		
P405	Network Fault	0	0 No Fault	Read only, see P425 and P426	
			1 Network Time-out, F _{nF} !		
P406	Proprietary		Module specific	Read only	
		i	NOTE: If this parameter returns a value of 16, the software version in this SMVector drive does not support the LECOM functionality. Contact factory technical support.		
P498	Missed Messages Drive to Module			Read only	
P499	Missed Messages Module to Drive			Read only	



4.2 RS485 LECOM-Specific Parameters

The parameters listed in Table 6 are only present in the drive if there is an RS485 communication module installed, P400 = 7 and the module is online (P402 = 3).

Table 6: RS485 LECOM-Specific Parameters

Code		Possible Settings		IMPORTANT
No.	Name	Default	Selection	
P410	Network address	1	1 99	The values 00, 10, 20, 30 ... 90 must not be used since they are reserved for group addressing (see section 6.4).
P411	Network Baud Rate	0	0 9600 bps 1 4800 bps 2 2400 bps 3 1200 bps 4 19200 bps	
P420	Network Control Level	0	0 Monitor Only 1 Parameter Programming 2 Programming and Setpoint Control 3 Full Control 4 Full Control (Special)	P420 = 2, 3: setpoint control using code number C0046 or C1061. P420 = 3, 4: drive control using code numbers C0040 and/or C0135 P420 = 4: setting C0140 = 0 results in Quick Stop Stop commands (QUICK STOP, INHIBIT) will always be accepted.
P424	Network Powerup Start Status	0	0 Quick Stop 1 Controller Inhibit	
P425	Network Message time-out	50	0 {ms} 65000	
P426	Network Message time-out action	0	0 No action 1 Controller Inhibit 2 Quick Stop 3 Trip Fault, F.nF1	
P427	Valid Network messages Received	0	0 {messages} 9999	<ul style="list-style-type: none"> • Read-only • When number of messages exceed 9999, counter resets and resumes counting from 0.
P494	Communication Module software version			<ul style="list-style-type: none"> • Read only • Format: x.yz
P495	Internal Code			<ul style="list-style-type: none"> • Read only • Alternating Display: xxx-; -yy



5 LECOM Protocol Details

5.1 LECOM - A/B Protocol Description

The LECOM-A/B protocol is used to exchange data between SMV controllers and a host. The LECOM-A/B protocol is based on DIN 66019, ISO 1745 and ANSI X3.28 (category 2.5 and A2, A4). These standards are similar to each other and describe the control mode of a transmission section of a transmission system.

The host (the master) can communicate with a slave (SMV controller) in three modes:

- RECEIVE (refer to 6.2)
- SEND (refer to 6.3)
- BROADCAST/MULTICAST (refer to 6.4)

The controllers communicate by means of the ASCII code:

	0	1	2	3	4	5	6	7	8	9	0	B	C	D	I	F
0	NUL	SOH	STX	ETX	EOT	ENQ	ACK	BEL	BS	TAB	LF	VT	FF	CR	SO	SI
1	DLE	DC1	DC2	DC3	DC4	NAK	SYN	ETB	CAN	EM	SUB	ESC	FS	GS	RS	US
2	space	!	“	#	\$	%	&	‘	()	*	+	,	-	.	/
3	0	1	2	3	4	5	6	7	8	9	:	;	<	-	>	?
4	@	A	B	C	D	E	F	G	H	I	J	K	L	M	N	O
5	P	Q	R	S	T	U	V	W	X	Y	Z	[\]	^	_
6	‘	a	b	c	d	e	f	g	h	i	j	k	l	m	n	o
7	p	q	r	s	t	u	v	w	x	y	z	{		}	~	DEL

Example:

“EOT” = 02_{hex} = 2_{dec}

Character “ 1 ” = 31_{hex} = 49_{dec}

5.2 Controller address (AD1, AD2)

One or more bus devices (slaves) can be selected by means of the controller address, which is 2 bytes (AD1, AD2) long. The LECOM-A/B protocol supports the broadcast telegrams, i.e. a telegram is sent to a group or all other bus devices. For this, controller addresses are reserved (refer to BROADCAST, 6.4). Controller addresses have the following structure:



The abbreviations have the following meanings:

AD1 ASCII ten-digit of the slave address (0 ... 9; 30 ... 39_{hex})

AD2 ASCII one-digit of the slave address (0 ... 9; 30 ... 39_{hex})



5.3 Code Number (C1, C2)

5.3.1 Standard Addressing

The meaning of the code numbers and the assigned parameters can be obtained from the code table (in section 9) and the SMV Operating Instructions Manual (SV01, section 10). When transmitting data, the code number is coded as follows:

The following calculation determines the two ASCII digits from the code number (value range: 0 ... 6229) (value range: $48_{dec} \dots 127_{dec}$):

$$C1 = \text{INTEGER}(\text{REMAINDER}(\text{code number}/790)/10) + 48_{dec}$$

$$C2 = \text{REMAINDER}(\text{REMAINDER}(\text{code number}/790)/10) + \text{INTEGER}(\text{code number}/790) \times 10 + 48_{dec}$$

The INTEGER is the digit before the decimal point, the REMAINDER is an integer.

Example: $13/5 = 2$ remainder 3
 $\text{INTEGER}(13/5) = 2$
 $\text{REMAINDER}(13/5) = 3$

Example: Convert code number 1002 in ASCII code C1 and C2:

$$C1_{ASCII} = \text{INTEGER}(\text{REMAINDER}(1002/790)/10) + 48 = \text{INTEGER}(212/10) + 48 = 21 + 48 = 69 = 45_{hex} = \text{“E”}_{ASCII}$$

$$C2_{ASCII} = \text{REMAINDER}(\text{REMAINDER}(1002/790)/10) + \text{INTEGER}(1002/790) \times 10 + 48 = \text{REMAINDER}(212/10) + 1 \times 10 + 48 = 2 + 10 + 48 = 60 = 3C_{hex} = \text{“<”}_{ASCII}$$

The code number C1002 is converted into the ASCII string “E<”, if they are transmitted to the controller by a host.

5.3.2 Addressing via Code Bank

With previous LECOM-A/B drivers, only code numbers in the range from 0 to 255 could have been addressed, since these drivers used only one byte as code number. To achieve the addressing of the wider code-number range with these drivers, use the code banking. The code-number range 0...255 is displayed as a window over the whole code-number range. This is controlled via the code C0249 (code bank). Code C0249 can always be accessed via number 249, independent of the currently set code bank.

Table 7: Code Bank Assignment

Code bank	Code offset	Code-number range
0	0	0 - 255
1	250	250 - 505
2	500	500 - 755
3	750	750 - 1005
4	1000	1000 - 1255
5	1250	1250 - 1505
6	1500	1500 - 1755
7	1750	1750 - 2005



NOTE

Code banking is only active when the standard addressing is being used. If the selected code numbers are higher than 255, the code-number range increases correspondingly. Only the corresponding code-number offset is selected by means of the code bank.

Example:

Set the code bank $\text{INTEGER}(1002/250) = 4$ in C0249 to address the code number 1002. C1002 is then accessed via the code number C02.



5.3.3 Addressing via Input Selection

Simple LECOM-A/B drivers, which only use the standard addressing, cannot address subcodes. The input selection C0248 has been developed to offer the possibility of addressing the subcodes. When using the standard addressing, the value entered in C0248 is always considered as the subcode. The code C0248 can always be accessed via number 248, independent of the currently set code bank and the sub code used.

Example:

Enter value 1 in C0248 to address the JOG value 1 in subcode 1. Now subelement 1 is always addressed when accessing C39.



NOTE

After a sub element has been accessed through C0248, C0248 should be reset to 0 to avoid the addressing of a subelement "by accident" when accessing another code.

5.3.4 Extended Addressing

Another possibility is the direct addressing of parameters by means of expanded addressing.

!	CH1	CH2	CH3	CH4	SC1	SC2
---	-----	-----	-----	-----	-----	-----

The abbreviations have the following meanings:

- ! The ASCII character "!" = $21_{hex} = 33_{dec}$ shows that the expanded addressing is used
- CH1 to CH4 Code number in hexadecimal code: each character corresponds to a nibble of the code numbers (CH1 is the highest, CH4 is the lowest nibble).
- SC1, SC2 Subcode number in hexadecimal code: each character corresponds to a nibble of the code number word (SC1 is the highest and SC2 the lowest nibble).

The following characters can be displayed in the ASCII code:

ASCII	0	1	2	3	4	5	6	7	8	9	A	B	C	D	E	F
Dec	48	49	50	51	52	53	54	55	56	57	65	66	67	68	69	70
Hex	30	31	32	33	34	35	36	37	38	39	41	42	43	44	45	46

A code number range from 0 to 65535 can be addressed by means of these characters. A maximum of 255 subelements (field elements) can be accessed via one subcode number of each code. Example: 1002 = "!03EA00"

5.4 Parameter Value (V1 to Vn)

Parameter values can be transmitted in four different formats with the following structures:

- ASCII decimal format (VD)

-	VK1	VK2	VK3	VK4	VK5	VK6	.	NK1	NK2	NK3	NK4
---	-----	-----	-----	-----	-----	-----	---	-----	-----	-----	-----

- ASCII hexadecimal format (VH)

H	VH1	VH2	VH3	VH4	VH5	VH6	VH7	VH8
---	-----	-----	-----	-----	-----	-----	-----	-----

- String format (VS)

S	VS1	VS2	VS3	VS4	VS5	VS6	...	VS240
---	-----	-----	-----	-----	-----	-----	-----	-------

- Octet string format for data blocks (VO)

0	VO1	VO2	VO3	VO4	VO5	VO6	...	VO240
---	-----	-----	-----	-----	-----	-----	-----	-------



The abbreviations have the following meanings:

VK1 to VK6	Integers
.	Decimal point (if required)
NK1 to NK4	Decimal codes (if required)
“H” (48hex)	Character [H], transfer of parameter values in the ASCII hexadecimal format
VH1 to VH8	1 to 8 hexadecimal characters each [0 to 9; A to F]
“S” (53hex)	Character [S], transfer of parameter values in the string format
VS1 to VS240	1 to 12 visible ASCII characters each (no control characters)
“O” (4Fhex)	Character [O], transfer of parameter values in the octet string format
VO1 to VO240	Data block in hexadecimal code; each character corresponds to a nibble of the data block

Parameter value in the ASCII decimal format (110)

The ASCII decimal format (VD) is most often used. The values consist of the following:

- 1 leading negative sign (if required)
- 6 digits before the decimal point (VK1 to VK6)
- 1 decimal point (if required)
- 4 digits after the decimal point (NK1 to NK4) (if required)

Values from -214748.3648 to 214748.3647 can be displayed.



NOTE

In the ASCII decimal format (VD), the decimal point must not be transmitted if the value does not have digits after the decimal point.

Parameter value in ASCII hexadecimal format (VH)

The LECOM-A/B protocol supports the transmission of hexadecimal parameter values with a length of:

- 2 characters (byte value)
- 4 characters (word/integer value)
- 8 characters (double word/long integer)

In the ASCII hexadecimal format, VH1 is the most significant and VH8 the least significant hexadecimal character.

Parameter value in the string format (VS)

By means of the string format (VS) of the protocol it is possible to transmit strings with a maximum of 20 characters in both directions.

The SMV inverter can only send the string parameters (e. g. C200).



Parameter values in the octet string format (VO)

The LECOM-A/B protocol includes the octet string format (VO) with which it is possible to transfer data blocks.

The character sequence corresponds to the filing in the memory (ascending order), i.e. the character transmitted first is the data block nibble with the lowest address. The data structure of the data block corresponds to the Intel-memory format with the following definition:

- BYTE: 1st high nibble
 2nd low nibble
- WORD: 1st high BYTE
 2nd low BYTE
- DWORD: 1st high WORD
 2nd low WORD

5.5 Block-Check Character (BCC)

The block-check character (BCC) is used to store the transmitted data and is generated according to DIN 66219 (chapter 3). Because of the program, the block-check character is generated by an XOR link from the following digits of the SEND telegram:

- it starts with the character directly after the STX control character
- it ends directly after the ETX control character
- BCC can accept the value 00 ... FF_{hex}.

EOT	AD1	AD2	STX	C1	C2	V1	0	Vn	ETX	BCC
			BCC							

or with expanded addressing:

	STX	“!”	CH1	CH2	0	SC2	ETX	BCC
		BCC						



6 LECOM Message Details

6.1 Telegram Response

The SMV controller must return an acknowledgement to the host. The only exceptions to this are when a broadcast telegram is received or when the controller address is not correct. These telegrams do not require an acknowledgement.

The SMV controller sends two types of acknowledgements:

- Negative acknowledgement (NAK = 15hex), if:
 - a fault (e.g. parity fault) was detected in one or more characters, including the character ENQ
 - an invalid command or variable address has been recognized
 - the variable value is not within the permissible range
- Otherwise, Positive acknowledgement (ACK = 06hex)

6.2 Receive Telegram

The command RECEIVE is to request parameter values of the SMV controllers. The code numbers of the requested parameter are transmitted via the RECEIVE telegram using the following structure:

EOT	AD1	AD2	C1	C2	ENQ
-----	-----	-----	----	----	-----

The abbreviations have the following meanings:

- EOT (04_{hex}) End of the (previous) transmission
- AD1, AD2 Logic unit address of the slave to be addressed Slaves
- C1, C2 Code number (two ASCII characters) or extended addressing
- ENQ (05_{hex}) Station request

6.3 Receive Telegram Response

The SMV controller addressed via a RECEIVE telegram generates one of the following responses:

- The controller could decode the request and is now sending the requested parameter value to the host.

STX	C1	C2	V1	0	Vn	ETX	BCC
-----	----	----	----	---	----	-----	-----

- The controller could decode the request, however, a check-sum fault (parity fault) occurred during transmission.

STX	C1	C2	?	ETX	BCC
-----	----	----	---	-----	-----

- The controller could not process the request because the requested code number does not exist.

STX	C1	C2	EOT
-----	----	----	-----

The abbreviations have the following meanings:

- STX (02_{hex}) Start of text
- C1, C2 Code number (two ASCII characters) or extended addressing
- V1 to Vn Parameter value (n ASCII characters)
- ETX (03_{hex}) End of text
- BCC Block-check character (00 ... FF_{hex})
- ? (3F_{hex}) ASCII character “?”
- EOT (04_{hex}) End of the (previous) transmission

Structure and meaning of the block-check character (BCC) are described in the corresponding paragraph of the chapter SEND.



Example 1

The current speed setpoint (code number C46) is to be read with the bus address 01 at the controller. The host sends the following RECEIVE telegram

EOT	0	1	4	6	ENQ
-----	---	---	---	---	-----

The controller can respond in three different ways:

STX	4	6	3	5	.	4	ETX	BCC
-----	---	---	---	---	---	---	-----	-----

Valid request: The current value of the parameter C46 is 35.4 (Hz) or

STX	4	6	?	ETX	BCC
-----	---	---	---	-----	-----

Invalid request: A check-sum fault (parity fault) occurred during data transmission or

STX	4	6	EOT
-----	---	---	-----

Invalid request: Parameter C46 does not exist in this controller.

6.4 Send Telegram

The command SEND is used to transmit data from the master to the slave. The master then sends a telegram with the following structure:

EOT	AD1	AD2	STX	C1	C2	V1	0	Vn	ETX	BCC
-----	-----	-----	-----	----	----	----	---	----	-----	-----

The abbreviations have the following meanings:

EOT (04 _{hex})	End of the (previous) transmission
AD1, AD2	Logic unit address of the slave to be addressed Slaves
STX (02 _{hex})	Start of text
C1, C2	Code number (two ASCII characters)
V1 to Vn	Parameter value (n ASCII characters)
ETX (03 _{hex})	End of text
BCC	Block-check character (00 ... FF _{hex})

In the text section of the telegram, which is embedded between the control characters STX and ETX, the code number (C1. C2) and the corresponding parameter value (V1 to Vn) are transmitted to the slave.

Example for a SEND telegram:

The maximum speed (code number C1103) is to be set to the value 95.2 Hz via the bus address 34 at the controller.

The host must send the following SEND telegram:

EOT	3	4	STX	0	1	9	5	.	2	ETX	BCC
-----	---	---	-----	---	---	---	---	---	---	-----	-----

The controller can respond with one of two acknowledgements:

ACK

The command was processed correctly. The current value of the parameter C1103 is 95.2 Hz or

NAK

The request could not be processed correctly. The value of parameter C1103 has not been changed.



6.4 Broadcast / Multicast

In a bus network, the command BROADCAST is to address all devices or a group of devices (multicast) at the same time. The structure of the BROADCAST telegram is similar to the structure of the SEND telegram. The only exception is that it does not return an acknowledgement.

The devices can be selected via their controller addresses. The controller addresses listed in Table 8 are reserved for a BROADCAST telegram.

Table 8: Controller Addresses for Broadcast Telegram

Controller address (reserved)	Controller address of groups	ASCII character	
		AD1	AD2
00	all	"0"	"0"
10	11 to 19	"1"	"0"
20	21 to 29	"2"	"0"
30	31 to 39	"3"	"0"
40	41 to 49	"4"	"0"
50	51 to 59	"5"	"0"
60	61 to 69	"6"	"0"
70	71 to 79	"7"	"0"
80	81 to 89	"8"	"0"
90	91 to 99	"9"	"0"

Example for a BROADCAST telegram:

All controllers are to be stopped when setting controller enable (code number C40 = 0).

The host sends the following BROADCAST telegram:

EOT	0	0	STX	4	0	0	ETX	BCC
-----	---	---	-----	---	---	---	-----	-----

The controllers do not return an acknowledgement.

Monitoring of the slave response:

The master monitors the selected slave. The slave must return a response within a defined time. Under the following circumstances the slave does not return a response to the master (time out):

- The controller address could not be recognized
- The transmission path is faulty
- A BROADCAST telegram had been sent.
- The hardware does not work properly

If the master does not receive a response within a defined period of time, the transmission is tried again. The number of repetitions is limited.

The monitoring time in the master should be approx. twice as long as the maximum response time.

Transmission faults

After a transmission fault, the master can read C0068 and evaluate the communication error in bit 4... 7.



7 Commissioning

7.1 Drive Monitoring

The network can always read drive parameters as long as the LECOM communications are enabled (i.e. P400 = 7) and configured properly (see P410-411). For monitor only operation, set P420 = 0.

7.2 Drive Programming and Control

Network Control must be enabled for the network to program drive parameters or take control of a drive. This is done by:

1. Setting P121...P124 equal to 09 (NET ENABLE) and asserting the corresponding TB-13x terminal
2. Setting P100 to 00, 01, 03, 04 or 06. Network control cannot be enabled when P100 is set to 02 (REMOTE KEYPAD ONLY) or 05 (TERMINAL STRIP/REMOTE KEYPAD).
3. Setting P420 to 01, 02 or 03.

7.3 Network Watchdog Timer

7.3.1 Watchdog Timer

The SMV is equipped with a Serial Link "Watchdog Timer". If the Watchdog Timer is enabled, the Master MUST PERIODICALLY COMMUNICATE with the drive or the timer will timeout.

Watchdog timer setup is performed by using parameters P425 and P426 (LECOM codes C1425 and C1426).

7.3.2 Watchdog Time-out Period (P425)

The maximum amount of time that should be allowed to pass between network messages to a specific drive will vary from one network to the next. Therefore, we have made the watchdog time-out period user settable via Drive Programming Parameter P425 (refer to section 4.2 for details).



NOTE

To prevent erroneous timeout trips, make sure the time set in parameter P425 (C1425) is appropriate for particular network - default value of 50ms might be too restrictive!

7.3.3 Watchdog Time-out Action (P426)

The appropriate action to be taken when a watchdog time-out occurs will also vary from one application to the next. Therefore, we have provided four user selectable time-out actions which can be set via Drive Programming Parameter P426.

The selections are:

- 0) No action Watchdog timer is disabled.
- 1) Controller inhibit If the drive doesn't receive valid communication for period longer than the time specified in parameter P425 (C1425), it will coast to stop and drive display will show inhibit state 'Stop'.
- 2) Quick Stop If the drive doesn't receive valid communication for period longer than the time specified in parameter P425 (C1425), it will ramp to stop and drive display will show stop state 'Stop'.
- 3) Trip fault 'F.nF1' If the drive doesn't receive valid communication for period longer than the time specified in parameter P425 (C1425), it trips with fault 'F.nF1'.



WARNING!

Disabling the watchdog timer may cause injury to personnel and/or damage to equipment. The watchdog timer should only be disabled during configuration or diagnosis to prevent nuisance timeout trips.



8 Drive Registers

8.1 Configuration and Control Registers

Registers #1 through #1099 are reserved for registers that are only available over the network and cannot be accessed via the drive's local keypad.

Table 9: Configuration & Control Registers

Code Number	Parameter Name	Default	Range of Adjustment		Important
C0040	Controller Inhibit	0	0	Controller inhibited	The controller can also be enabled with the control word C0135
			1	Controller enabled	
C0043	Fault Reset	0	0	No Action	The fault can also be reset with the control word C0135
			1	Reset Fault	
C0046	Frequency Setpoint		0.0	... 500.0 Hz	Read only
C0050	Actual Output Frequency		0.0	... 500.0 Hz	Read only
C0068	Operating Status Bit Word		Bit	Description	Read only
			0-3	The 10th digit of the LECOM fault number is displayed. Example: TRIP OH = 5 (LECOM no. = 50)	
			4-7	Last communication error 0 = No fault 1 = Check sum error 2 = Protocol frame error 3 = Reserved 4 = Invalid code number 5 = Invalid variable 6 = No access permission 7 = Telegram processing interrupted by a new telegram 15 = General fault	
			8	Control via LECOM enabled	
			9	Actual frequency above threshold C17	
			10	Direction of rotation 0 = CW 1 = CCW	
			11	Power stage transistors energized	
			12	Quick STOP active	
			13	Current Limit	
			14	Setpoint frequency reached	
			15	Fault occurred	
			LECOM Format = VH		



Commissioning

Code Number	Parameter Name	Default	Range of Adjustment		Important
C0135	Controller Control Word		Bit	Description	
			0-1	JOG1, JOG2, JOG3 0 = C0046 active 1 = JOG1 (C0037) active 2 = JOG2 (C0038) active 3 = JOG3 (C0039) active	
			2	Rotation command 0 = CW 1 = CCW	
			3	Quick Stop 0 = QSP not active 1 = QSP active	
			4-8	Reserved	
			9	Controller inhibit 0 = No controller inhibit 1 = Controller inhibit	
			10	Reserved	
			11	Trip fault reset 0 -> 1 Edge from 0 to 1 causes TRIP reset	
			12-13	Reserved	
			14	DC Brake (DC injection brake) 0 = DCB not active 1 = DCB active	
			15	Reserved	
			LECOM Format = VH		
C0140	Frequency Setpoint Command	0.0 Hz	0.0 ... 500.0 Hz		



Code Number	Parameter Name	Default	Range of Adjustment		Important
C0150	Controller Status Word		Bit	Description	Read only
			0	Reserved	
			1	Power stage transistors energized	
			2	Current Limit reached	
			3	Reserved	
			4	Setpoint Frequency reached	
			5	Actual frequency above threshold C17	
			6	Actual frequency == 0Hz	
			7	Controller inhibit 0 = No controller inhibit 1 = Controller inhibit	
			8 - 11	Controller status 0 = No error 1 = Error	
			12	Overtemperature fault	
			13	DC Bus overvoltage	
			14	Direction of rotation 0 = CW 1 = CCW	
			15	Read for operation 0 = fault (not ready for operation) 1 = no fault (ready for operation)	
			LECOM Format = VH		



Commissioning

Code Number	Parameter Name	Default	Range of Adjustment	Important
C0200	Software Identification		Software identification string: example "33SSSMD-M_14000" LECOM Format = VS	Read only
C0201	Software Generation Date		Software generation date: example "2008-10-18" LECOM Format = VS	Read only
C1050	Network Controlled Digital Output (TB14) + Relay		0 = de-energized 1 = energized bit 9: TB-14 state bit 10: Relay state other bits are not used	Refer to section 8.1.1
C1055	Network Controlled Analog Output	0.0%	0.0 ... 100.0	Refer to section 8.1.2
C1060	Keypad Speed Command	20.0 Hz	P102 ... P103	
C1061	Network Speed Command	0.0 Hz	P102 ... P103	
C1070	Keypad PID Setpoint Command	0.0	-99.9 ... 3100.0	Read only
C1071	Network PID Setpoint Command	0.0	-99.9 ... 3100.0	Read-only
C1072	Actual PID setpoint	0.0	-99.9 ... 3100.0	Read only
C1073	PID Setpoint Command	0.0	-99.9 ... 3100.0	Read only
C1074	PID Feedback	0.0	-99.9 ... 3100.0	Read only
C1080	Keypad Torque Command	100%	0.0 ... 400.0	
C1081	Network Torque Command	0%	0.0 ... 400.0	
C1099	Parameter Version			Refer to section 8.1.3

8.1.1 C1050 (Network Controlled Digital Output)

To control the state of the relay or digital output (TB14), Drive Programming Parameter P140 and/or P142 must be set to 25 (Network Controlled).

8.1.2 C1055 (Network Controlled Analog Output)

To control the state of the analog output (TB30), Drive Programming Parameter P150 must be set to 09 (Network Controlled).

8.1.3 C1099 (Parameter Version)

The Parameter Version identifies the parameter set for the current version of software. If the Parameter version is different between two drives, it could indicate that a register has been added or deleted, a register's min/max limits have changed, a register's function has been changed, or a register's default value has been changed.



9 Programming Parameters

There is an offset of 1000 between the Drive Programming Parameter numbers and the code numbers used in the LECOM messages. For example, if you want to read Drive Programming Parameter P103 (Maximum Frequency) over the LECOM network, you would read code number 1103.

9.1 Fault History (P500)

Value	Display	Fault Message
0		No Fault
1		TMP Output Fault
2	<i>F_DF</i>	Output (Transistor) Fault
3	<i>F_DF1</i>	Ground Fault
4	<i>F_RF</i>	High Drive Temperature
5	<i>F_rF</i>	Flying Start Fault
6	<i>F_HF</i>	High DC Bus Voltage
7	<i>F_LF</i>	Low DC Bus Voltage
8	<i>F_PF</i>	Motor Thermal Overload
9	<i>F_GF</i>	OEM Fault
10	<i>F_IL</i>	Illegal Setup
11	<i>F_dbF</i>	Dynamic Brake Over Temperature
12	<i>F_SF</i>	Single Phase Fault
13	<i>F_EF</i>	External Fault
14	<i>F_CF</i>	Control Fault
15	<i>F_UF</i>	Start Error (Power loss)
16	<i>F_cF</i>	Incompatibility Fault
17	<i>F_F1</i>	Internal Fault 1 (EPM)
18	<i>F_F2</i>	Internal Fault 2
19	<i>F_F3</i>	Internal Fault 3
20	<i>F_F5</i>	Internal Fault 5 (stack overflow)
21	<i>F_F5</i>	Internal Fault 5 (stack underflow)
22	<i>F_F6</i>	Internal Fault 6
23	<i>F_F7</i>	Internal Fault 7
24	<i>F_F8</i>	Internal Fault 8
25	<i>F_F9</i>	Internal Fault 9
26	<i>F_bF</i>	Personality Fault
27	<i>F_F12</i>	Internal Fault (AD Offset)
28	<i>F_JF</i>	Internal Fault (Remote Keypad Lost)
29	<i>F_RL</i>	Assertion Level switched during Operation Fault
30	<i>F_F4</i>	Internal Fault 4 (FGD Missing)
31	<i>F_F0</i>	Internal Fault 0 (PW Missing)
32	<i>F_FoL</i>	Follower Lost
33	<i>F_F11</i>	ISO Comm Fault
34	<i>F_nbF</i>	Internal Fault (Module Communication (SPI) Timeout)
35	<i>F_Fnr</i>	Internal Fault (FNR: Invalid Message Received)
36	<i>F_nF1</i>	Network Time-out



9.2 Drive ID (P502)

This register returns an index value that is associated with the voltage and power rating of the drive. Table 10 lists the drive configuration by Index number.

Table 10: Drive ID

Index	Input Voltage	Power Rating	
8	240 VAC, Single-Phase	0.33 HP (0.25 kW)	
12	240 VAC Single or Three-Phase	1.5 HP (1.1 kW)	
13		2 HP (1.5 kW)	
14		3 HP (2.2 kW)	
21	240 VAC Three-Phase	0.5 HP (0.37 kW)	
23		1 HP (0.75 kW)	
24		1.5 HP (1.1 kW)	
25		2 HP (1.5 kW)	
26		3 HP (2.2 kW)	
28		5 HP (4 kW)	
29		7.5 HP (5.5 kW)	
30		10 HP (7.5 kW)	
31		15 HP (11 kW)	
32		20 HP (15 kW)	
42		480 VAC Three-Phase	0.5 HP (0.37 kW)
44	1 HP (0.75 kW)		
45	1.5 HP (1.1 kW)		
46	2 HP (1.5 kW)		
47	3 HP (2.2 kW)		
49	5 HP (4 kW)		
50	7.5 HP (5.5 kW)		
51	10 HP (7.5 kW)		
52	15 HP (11 kW)		
53	20 HP (15 kW)		
54	25 HP (18.5 kW)		
55	30 HP (22 kW)		
69	600 VAC Three-Phase		1 HP (0.75 kW)
71		2 HP (1.5 kW)	
72		3 HP (2.2 kW)	
74		5 HP (4 kW)	
75		7.5 HP (5.5 kW)	
76		10 HP (7.5 kW)	
77		15 HP (11 kW)	
78		20 HP (15 kW)	
79		25 HP (18.5 kW)	
80		30 HP (22 kW)	
91		120 or 240 VAC Single-Phase	0.33 HP (0.25 kW)
92			0.5 HP (0.37 kW)
94	1 HP (0.75 kW)		

All unused Index values are reserved for future use



9.3 Terminal and Protection Status (P530)







When a read command is issued over the LECOM network to Programming Parameter P530 (code number 1530), the Terminal and Protection Status data returned can be interpreted as follows:







Data Low Byte	0	TB-13D Input Status
	1	reserved
	2	Protection Status
	3	Fast Current Limit Status
	4	Input TB-1 Status
	5	reserved
	6	TB-13A Input Status
	7	TB-13B Input Status

Data High Byte	8	TB-13C Input Status
	9	TB-14 Output Status
	10	Relay Output Status
	11	Charge Relay State
	12	Assertion Level Switch State
	13	reserved
	14	reserved
	15	reserved

9.4 Keypad Status (P531)

When a read command is issued over the LECOM network to Programming Parameter P531 (code number 1531), the Keypad Status data returned can be interpreted as follows:

Data Low Byte LOCAL Drive Keypad	0		UP Push-button State
	1		DOWN Push-button State
	2		MODE Push-button State
	3		FWD/REV Push-button State
	4		STOP Push-button State
	5		START Push-button State
	6		CTRL Push-button
	7		Unused

Data High Byte REMOTE Keypad	8		UP Push-button State
	9		DOWN Push-button State
	10		MODE Push-button State
	11		FWD/REV Push-button State
	12		STOP Push-button State
	13		START Push-button State
	14		CTRL Push-button
	15		Unused



10 Troubleshooting and Fault Elimination

10.1 Faults

Table 11 lists the faults common to the LECOM communications module.

Table 11: Faults

Fault Code	Fault	Cause	Remedy
F _{net} F	Module to Drive communication time out	Connection between drive and module is not made.	Check cable and connection between module and drive
F _{net} I	Network Time-out Fault	Drive under NETWORK control and network communications have been lost.	See parameters P425, P426

10.2 Troubleshooting

Table 12 lists some common LECOM communications problems and possible corrective action.

Table 12: Troubleshooting

Symptom	Possible Cause	Remedy
No communication from the drive	Module is not initialized properly	<ul style="list-style-type: none"> Verify the module connection Check P400 and P402
	Incorrect LECOM settings	<ul style="list-style-type: none"> Use P403 to reset LECOM parameters. Verify P410 and P411
	Improper wiring	<ul style="list-style-type: none"> Check wiring between the LECOM Network and communication module. Ensure that terminal block is properly seated. Check connection between module and drive.
LECOM write commands are ignored or return exceptions.	“Network Enabled” terminal is either open or not configured.	Configure one of the input terminals (P121 ... P124) to “Network Enabled” function (selection 9) and close the corresponding contact.
	Network Control Level set to monitor only (P420 = 0)	Set P420 = 1, 2, 3 or 4
Drive stops without obvious reason	LECOM message monitoring time-out occurred. The timeout reaction is set to Quick stop or Inhibit.	Modify the setting of time-out time (P425) or the reaction to the time-out (P426).

Lenze AC Tech Corporation

630 Douglas Street • Uxbridge, MA 01569 • USA
Sales: (508) 278-9100 • Service (508) 217-9100
www.lenzeamericas.com

Document
CMVLC401A-en1